

**ALPHA**

THE ALL-NEW

**M5**

SMART Technology

SMARTER Showering



Model : M5E  
M5EP  
M5i



ALPHA M5E/EP/i (M) H01A00118 (14.8cm(W) x 21cm(H)\_ 12.05.2018

- Thank you for purchasing **ALPHA** Instant Water Heater, please read this manual thoroughly and understand the terms before use. After reading keep this manual handy for future reference.

### SIGNAL EXPLANATION



#### SAFETY PRECAUTION

Indicating when product is used wrongly, user may get serious injure or damage to property.  
Please read carefully and follow the specified note.



#### SAFETY PRECAUTION

1. Do not install reverse INLET and OUTLET of heater.

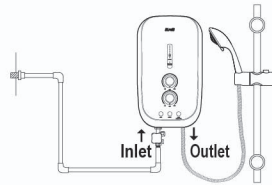

2. Do not install heater in consistent spray directly.



3. Do not use heater if ELCB AUTO TEST or LINE FAULT indicator show in RED light.

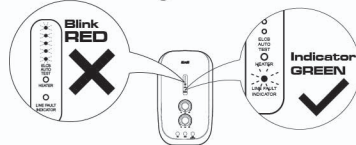

4. Do not block heater OUTLET in any way.

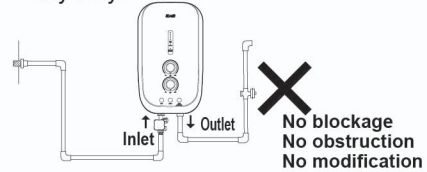

5. Do not attempt repair unit yourself.

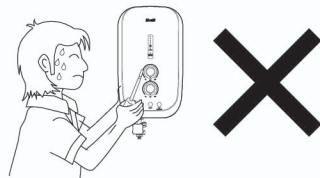

6. Do not leave children, elderly or disable person alone in shower.

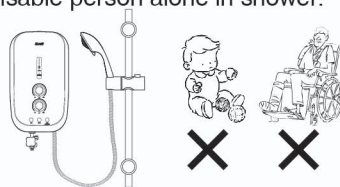

7. Engage qualified electrician for installation.



8. Test the water temperature with hand before stepping into shower.



## PART DESCRIPTION: M5 SERIES HEATER

### EXTERNAL PART IDENTIFICATION

#### M5EP / M5i

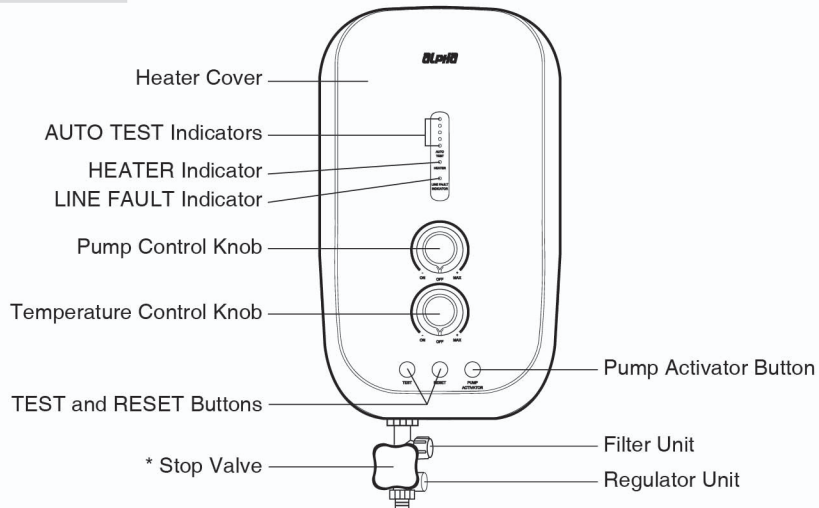

#### M5E

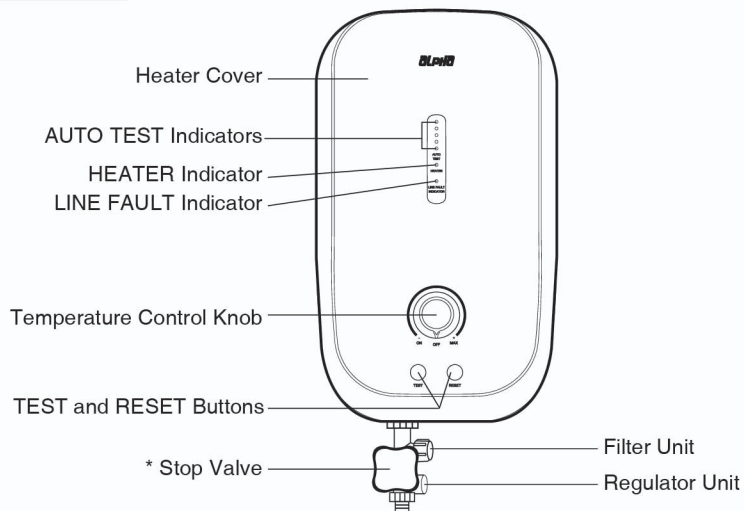

\* The design of the stop valve may look different from the picture shown in the manual as it is subjected to requirements from different countries.

## PART DESCRIPTION: M5 SERIES HEATER

### INTERNAL PART IDENTIFICATION

#### M5EP / M5 i

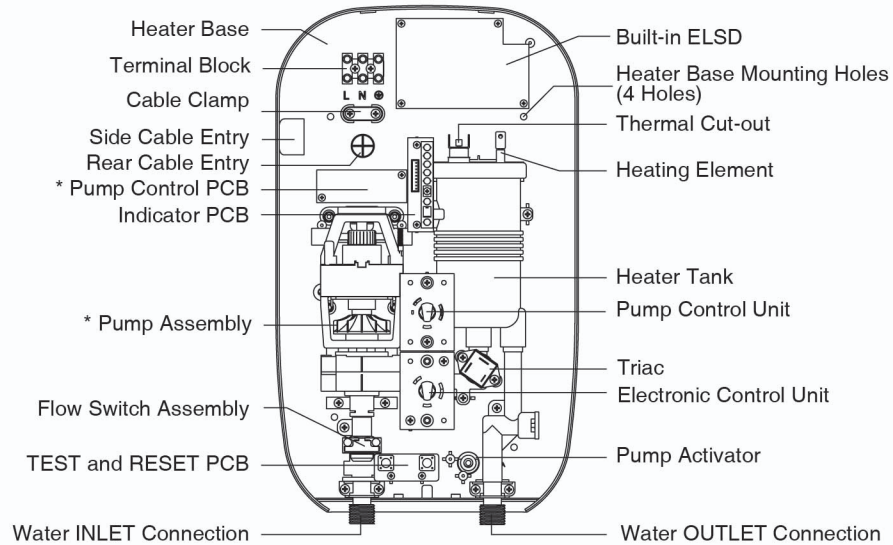

#### M5E

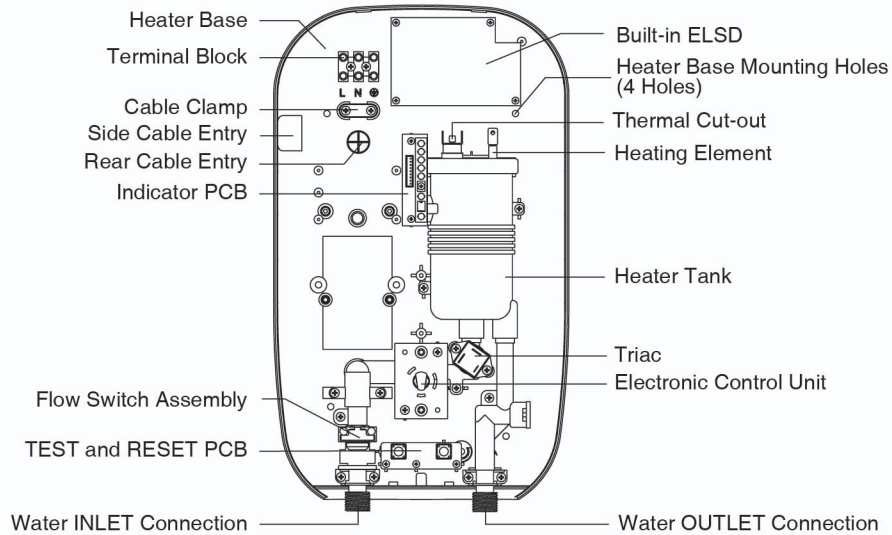

\* Diagrams of AC Pump and DC Pump are different from one another. The diagrams shown above are for reference only.

## PART DESCRIPTION: M5 SERIES HEATER

### ACCESSORIES

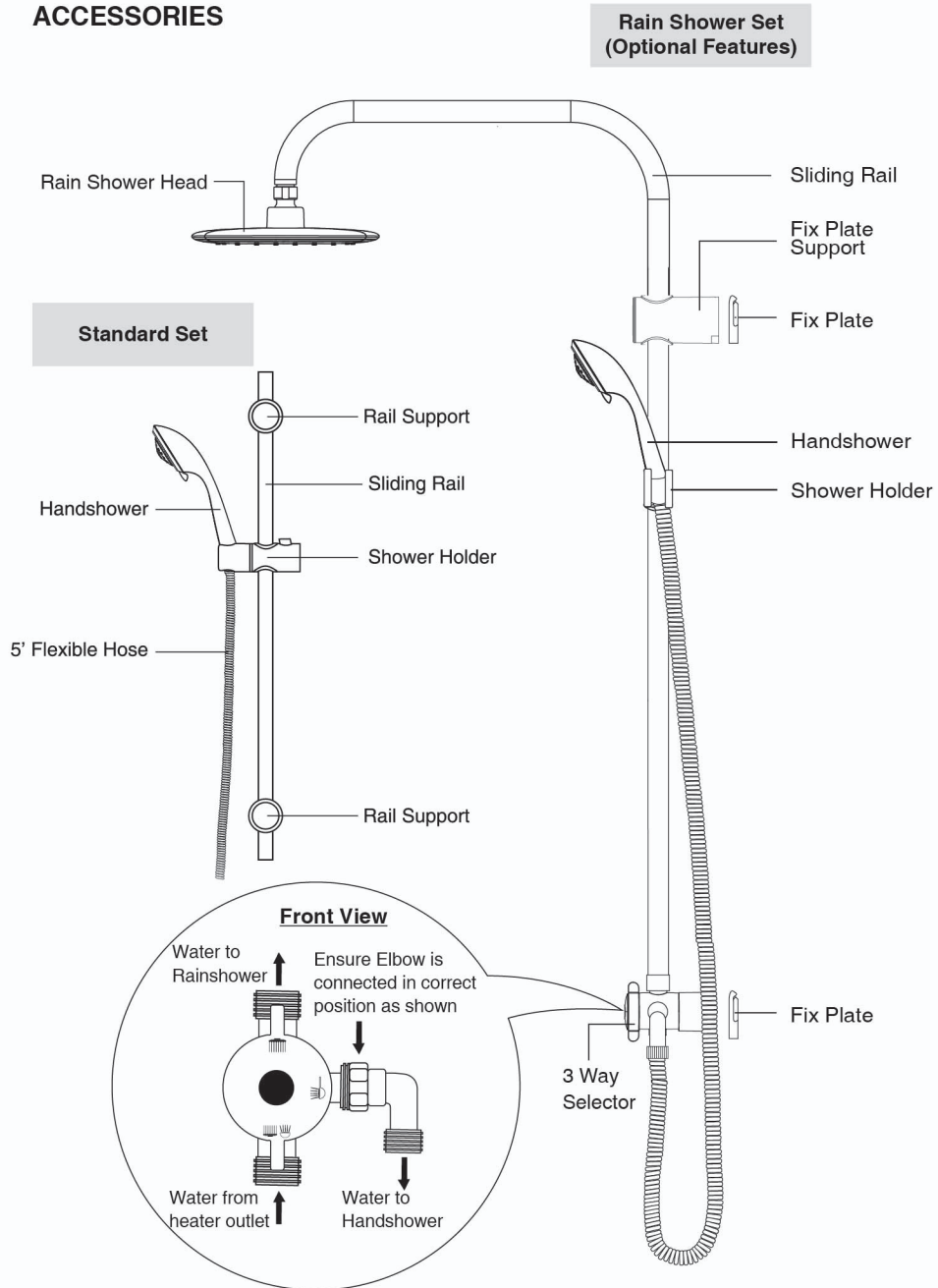

## GENERAL INFORMATION

### ELECTRICAL:



**CAUTION:**  
**THIS APPLIANCE MUST BE EARTHED.**

1. All wiring **MUST** conform to local regulations. If in doubt, always consult a qualified electrician.
2. Installation must be carried out by a qualified electrician.
3. The heater must be permanently connected to the electricity supply through a double pole linked switch having a contact separation of at least 3mm in all poles incorporated in the circuit, and out of reach from the person using the shower.
4. The use of plug and socket is not allowed.
5. Correct size of wire conductor corresponding to different electrical loading shall be used.

Voltage (V~)	Power (kW)	Amperes (A)	Recommended Conductor Size (csa)			Fuse/ MCB (A)	ON/OFF Switch (A)
			mm	Comduit Cable	Flexible Cable		
220 - 50/60Hz	3.5	16.0	4.0	7/0.85mm	56/0.30	20	20
	4.5	20.5	4.0	7/0.85mm	56/0.30	25	25
	5.5	25.0	4.0	7/0.85mm	56/0.30	32	32
	6.0	27.3	4.0	7/0.85mm	56/0.30	32	32
	6.5	29.6	4.0	7/0.85mm	56/0.30	40	40
	7.5	34.1	6.0	7/1.04mm	84/0.30	40	40
230 - 50/60Hz	8.0	36.4	6.0	7/1.04mm	84/0.30	40	40
	3.5	15.2	4.0	7/0.85mm	56/0.30	20	20
	5.5	24.0	4.0	7/0.85mm	56/0.30	32	32
	6.6	28.7	4.0	7/0.85mm	56/0.30	32	32
240 - 50/60Hz	8.8	38.3	6.0	7/1.04mm	84/0.30	45	45
	3.6	15.0	4.0	7/0.85mm	56/0.30	20	20
	4.2	17.5	4.0	7/0.85mm	56/0.30	20	20
	7.1	29.6	4.0	7/0.85mm	56/0.30	40	40
	9.5	39.6	6.0	7/1.04mm	84/0.30	45	45

Table 1: Electrical Loading Table

6. A typical electrical wiring connection is shown in diagram 1.

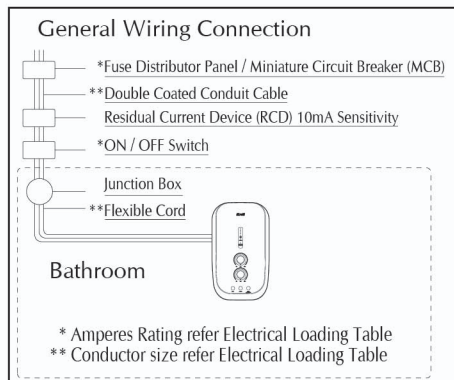

Diagram 1

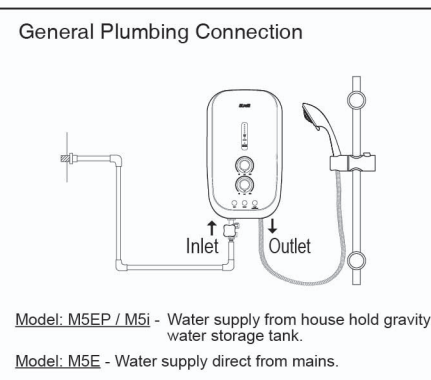

Diagram 2

## GENERAL INFORMATION

### **WATER:**

1. The heater works at a minimum water flow rate of 3 litre/min. Note that for heater model without built-in pump an incoming water with consistently flow rate of 5 liters/min and above would excel its performance.
2. A typical plumbing connection is shown in diagram 2.

### **SAFETY:**

**Note:** An approved type of Residual Current Device (RCD) of 10mA sensitivity should be installed in conjunction with the heater.

1. The built-in Earth Leakage Sensing Device (ELSD) will cut off the power supply to the heater in the event of current leakage of as low as 15mA.
2. Upon power on at mains, the heater will perform 10 seconds 'self-test' routine. If the ELSD is in proper working condition after the 'self-test', the AUTO TEST indicators will light up GREEN and heater will be in power. If ELSD is faulty, its AUTO TEST indicators will blink RED and power will be cut off from heater.
3. The built-in Line Fault Detector will indicate 'GREEN' light if wiring is done correctly or 'RED' light if improper electrical wiring is detected.
4. The heater operates when there is sufficient water to trigger the Flow Switch.
5. The Thermal cut-out would automatically breaks off the power supply if there is abnormal rise in the water temperature during shower.
6. Heater casing designed to high degree of protection IP25 prevents water from entering into the heater during shower.

### **IMPORTANT NOTE:**

1. This heater is tested suitable for use in the shower cubicles. However, do not install the heater unit where is consistent spray directly over the unit.
2. If the heater's ELSD trips during normal operation, switch off the mains supply and contact the service centre for repair(s).
3. If the Auto Test and Line Fault Indicator indicate RED light, switch off the mains supply and contact a qualified electrician to check the electrical supply line (refer Page 11 for possible cause(s)).
4. In the event if the heater malfunctioned, never attempt to repair the unit yourself.
5. The outlet point of this heater, hose and handshower act as a vent. They must not be blocked, obstructed or modified in any way. Fittings not recommended by manufacturer must not be connected. The use of unapproved accessories may not only affect its performance and safety of the user but also voids its warranty.
6. If there is a sudden reduction of incoming water, the shower temperature will increase. This does not indicate the fault of the heater. Adjust the Temperature Control Knob (to reduce heating power) or Regulator Unit (to increase flow) in order to get the desired shower temperature.
7. Always test the water spray temperature with your hand before stepping into the shower.
8. This appliance is not intended for use by persons (including children) with reduced physical, sensory or mental capabilities, or lack of experience and knowledge, unless they have been given supervision or instruction concerning use of the appliance by a person responsible for their safety.
9. Do not leave your children, elderly, infirm or disable persons unattended in the shower.

## INSTALLATION PROCEDURES

### IMPORTANT:

- All plumbing work shall be completed before proceeding to electrical wiring connection.
- Metallic / Chromed hose and conductive control valve shall not be used (in Malaysia only- Malaysian government's regulations. Optional for others).
- Heater outlet shall not be connected to any tap or fittings not recommended by manufacturer.
- The heater unit must be installed on solid wall to avoid the possibility of distorting the unit.
- Inlet and Outlet connections of the heater must not be reversed.

### 1. Decide the mounting position:

- Turn off the water source.
- Remove screw at the bottom of the heater.
- Remove Heater Cover by lifting the bottom upward.
- Mark out 4 mounting points on the wall.

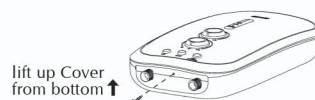

### Note:

*It is recommended that mount the bottom of the heater be 1.50 meters / 5 feet above the floor of the bathroom. However the height of the installation level is at the discretion of the user.*

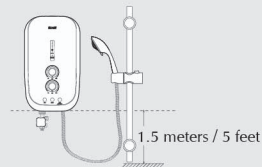

### 2. Mounting of the heater:

- Drill the 4 holes with 5.0mm diameter drill bit.
- Put in the wall plugs and install the heater to the wall with screws provided.

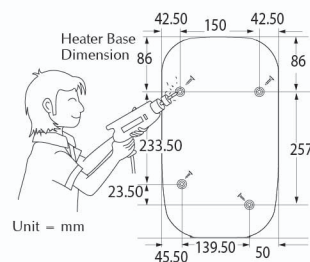

### 3. Shower Accessories Installation:

- Fix the Shower Holder and Rail Supports (Top and Bottom) on to the Sliding Rail.
- Mark the positions of the 2 holes of the Rail Supports - be sure that the top portion is in level or not higher than the top of the heater.
- Drill the holes and mount the shower accessories with wall plugs and screws provided. Insert the Rail Support Caps on to the Rail Supports.

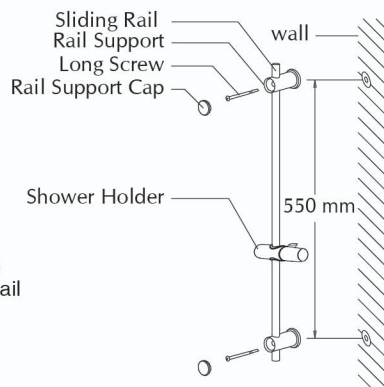



## INSTALLATION PROCEDURES

### 4 Connection of heater Inlet and Outlet:

- Connect Stop Valve to heater Inlet with use of the rubber seal provided.
- Connect incoming water supply to Stop Valve. If necessary make use of the sealing tape to prevent water leaking.
- Connect Flexible Hose to heater Outlet. *(Do not connect the other end of flexible hose to handshower at this stage).*
- Turn on the water supply to drain out all the plumbing dirt and to fill up the heater tank. *(This step will prevent damage to Heating Element.)*
- Connect the other end of flexible hose to handshower - be sure to put in the Filter Mesh Washer in order to prevent dirt from entering the handshower.

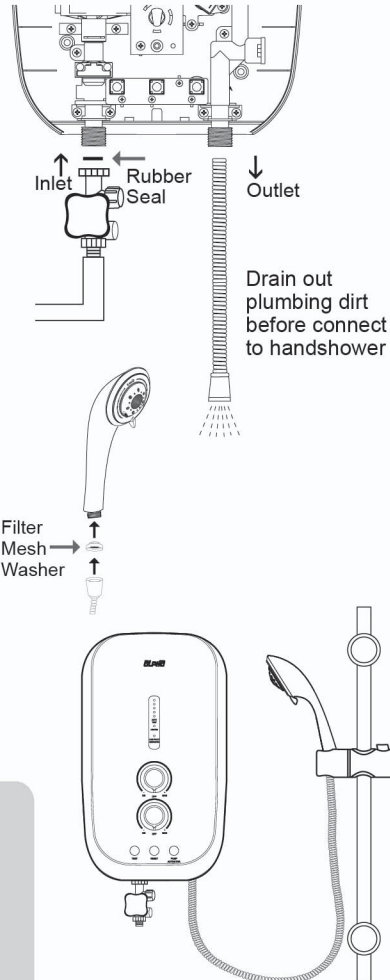

#### Note:

- Do not apply excessive force to tighten any of the connections.
- Excessive force may cause damage to the connector.
- Do not bend the Flexible Hose or install any accessories which can block the water flow at heater outlet.

## INSTALLATION PROCEDURES

### 5 Electrical Connection:



**CAUTION:**

**Make sure the electrical mains is off before carrying on the electrical work.**

- Insert electrical cable through the rubber grommet for side entry or wall embedded entry.
- Connect cable to Terminal Block and fully tighten them as follows:
  - RED or BROWN ..... LIVE (L)
  - BLACK or BLUE ..... NEUTRAL (N)
  - GREEN/YELLOW or
  - YELLOW/GREEN ..... EARTH (⊕)

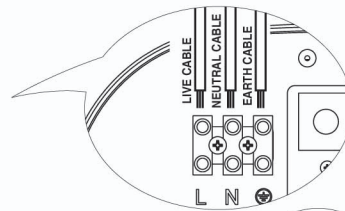
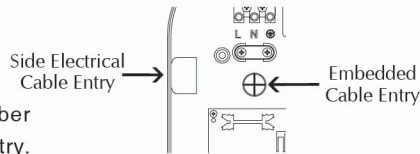

- Replace the Heater Cover:
  - To ensure correct position, turn the Electronic Control Unit and Pump Control Unit (at Heater Base) to the off position (as shown in picture).
  - Install the heater cover and ensure that the Temperature Control Knob and Pump Control Knob are aligned (point to 'OFF') to their control unit accordingly.
  - Secure the screw as shown.

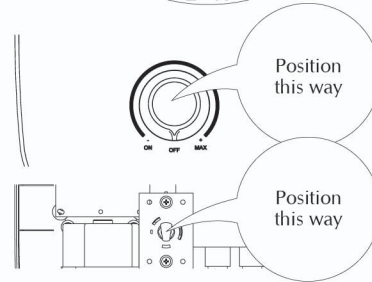

### 6 Test Run Of Heater:

- Turn on Stop Valve.
- Switch on heater switch. The 'AUTO TEST' and 'LINE FAULT INDICATOR' will light up. **Proceed to step (c) if 'AUTO TEST' and 'LINE FAULT INDICATOR' displays green light.**



**CAUTION:**

**Stop using the heater and check the wiring if 'AUTO TEST' and 'LINE FAULT INDICATOR' displays RED light (refer page 11 for possible causes).**

- Turn on the Temperature Control Knob. The 'HEATER' indicator will light up. The water should be warm in a few seconds.
- The water would get warmer as the Temperature Control Knob is turned clockwise.
- Check the built-in ELCB as follow:
  - Press 'TEST' button: unit should trip and cut off power supply.
  - Press 'RESET' button: unit should resume normal function.
 If the above mentioned steps prevail, the ELCB is functioning normally.

## OPERATING PROCEDURES

- 1 Switch on the heater switch outside the bathroom. The 'AUTO TEST' and 'LINE FAULT' indicator would light up.



**CAUTION:**  
'AUTO TEST' and 'LINE FAULT INDICATOR' must indicate green.  
Otherwise the unit must not in use and contact agent for repair.

- 2 Turn on the Stop Valve. Adjust the Regulator Unit for suitable water shower volume.
- 3 Turn on Temperature Control Knob. The 'HEATER' indicator would light up. The shower would get warmer as the knob is turned clockwise from 'ON' to 'MAX'.
- 4 Normal cold shower can be selected by setting the Temperature Control Knob to 'OFF' position.
- 5 Switch off the heater switch when not in use.

### Note:

- The shower water may not be hot enough even at 'MAX' in areas whereby the water pressure is exceptionally high and cold. This can be remedied by reducing the water inflow or replacing the unit with one that is of higher power (if it is approved by relevant authorities).
- The built-in Pump can be independently controlled by using the Pump Control Knob. In low pressure areas (below 15 p.s.i.), adjust pump speed to obtain desired spray of water. If water pressure is high (over 15 p.s.i.), turn "OFF" the Pump Control Knob to achieve hotter shower. (Model M5EP/M5i)
- The Pump Activator is specially designed for low pressure areas whereby the water pressure is too weak to trigger the Built-in shower Pump. Just press the Pump Activator Button and the Shower Pump will spring into action. (Model M5EP/M5i)
- It is recommended that the pump be operated at intervals of 30 minutes with 30 minutes rest in between. (Model M5EP/M5i)

## CUSTOMER GUIDANCE:

<p>a) Connection of heater INLET:</p> <p>Connect Stop Valve to INLET</p>	<p>b) Connection of heater OUTLET:</p> <p>Connect Flexible Hose to OUTLET</p>
<p>c) Temperature Control Knob:</p> <p>Temperature Control Knob</p> <p>Turn to reduce heater power.</p> <p>Turn to increase heater power.</p>	<p>d) Built-in ELSD:</p> <p>Check the ELSD at least once a month as follow: Turn on electric and water supply to the heater.</p> <ul style="list-style-type: none"> <li>• Press TEST button: Heater would trip and power go off.</li> <li>• Press RESET button: Heater power would resume.</li> </ul> <p>Contact service centre for repair if there is malfunction.</p>
<p>e) Stop Valve:</p> <p>OFF</p> <p>ON</p>	<p>f) Regulator Unit:</p> <p>Turn to increase water volume</p> <p>Turn to reduce water volume</p> <p>Stop Valve Regulator</p> <p>Adjust clockwise to reduce water inflow if shower temperature not hot enough even at 'MAX' power setting.</p>

## OPERATING PROCEDURES

### g) LINE FAULT INDICATOR: (Optional)

Red Warning Light shows if there is an improper electrical connection.

Possible Causes:

- Earth wire not connected to heater.
- Live and Neutral phases are reversed.
- Earth conductor not grounded (floating) or having high resistance to ground.



**Warning: Improper earthing may result in malfunctioning to the RCD/ELCB. Never use the heater if there is doubt on the Earthing installation.**



Green light indicates proper electrical connection.

### h) Shower Accessories

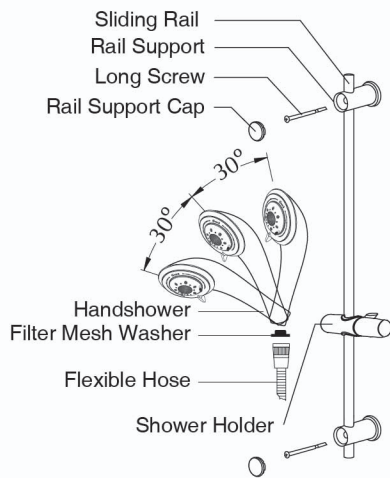

#### Rain Shower Set (Optional)

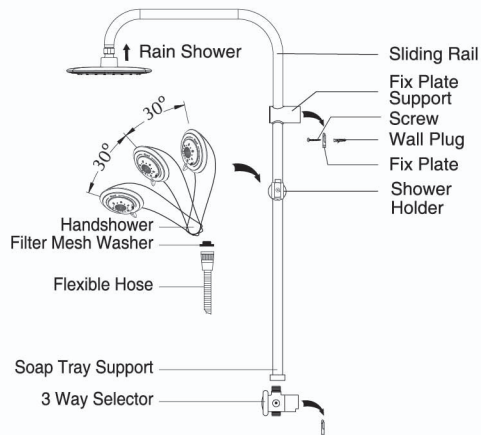

## MAINTENANCE:



### DO NOT USE THINNER, ALCOHOL OR PETROL

You may clean the heater with a damp cloth and mild detergent but do not use thinner, alcohol, petrol or any other corrosive solutions.

#### a) Stop Valve

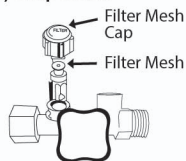

### CLEAN FILTER REGULARLY

The filter should be cleaned whenever there is a sign of inlet water blockage.

#### a) Stop Valve

Remove Filter Mesh Cap. Pull out Filter Mesh and flush it with water to remove any trapped sediments. Slot it back to its original position before securing it with Filter Mesh Cap.

#### b) Handshower

Disconnect the handshower from the hose. Remove Filter Mesh Washer and flush it with water to remove any trapped sediments. Re-connect the handshower to the hose in its original position.

#### b) Handshower



#### Note:

- Make sure to turn off the incoming water supply before the operation.
- This has to be done more regularly in area where the inlet water supply is dirty.
- The design of the stop valve may look different from the picture shown in the manual as it is subjected to requirement from different countries.

## RAIN SHOWER (Optional Feature)

### Installation of Rain Shower Accessories (Optional Feature)

#### Step 1

Drill the holes according to dimensions as shown (2 holes). Insert Wall Plug to the hole after drilling.

The height of the installation is at the discretion of the user. The installation height should take consideration of the tallest user and the connection Hose of the Handshower should be able to reach from top to bottom of the Sliding Rail.

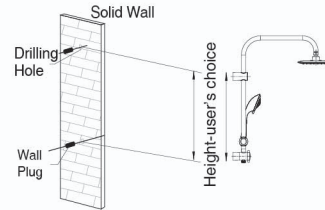

#### Step 2

Secure the Fix Plate (2 units) with screws provided.

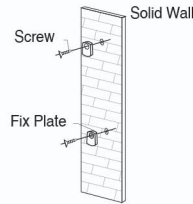

#### Step 3

Secure the 3 Way Selector into Sliding Rail.

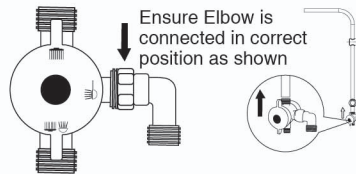

#### Step 4

Place the Rain Shower Set by insert the Fix Plate Support into Fix Plate (Ensure first is to secure the bottom Fix Plate then follow by top Fix Plate).

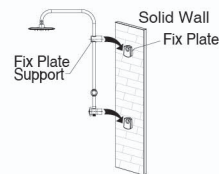

#### Step 5

Connect 2.5' Flexible Hose from heater outlet to bottom connection of 3 way selector.

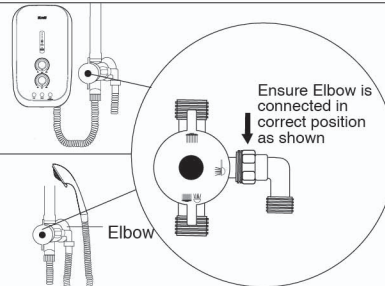

#### Step 6

Connect 5' Flexible Hose from Elbow of 3 way selector to Handshower.

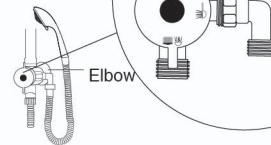

#### Step 7

Select type of water spray you desire:

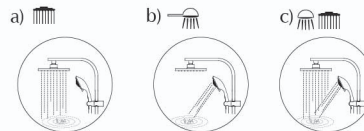

## GENERAL INFORMATION

### SCHEMATIC WIRING DIAGRAM

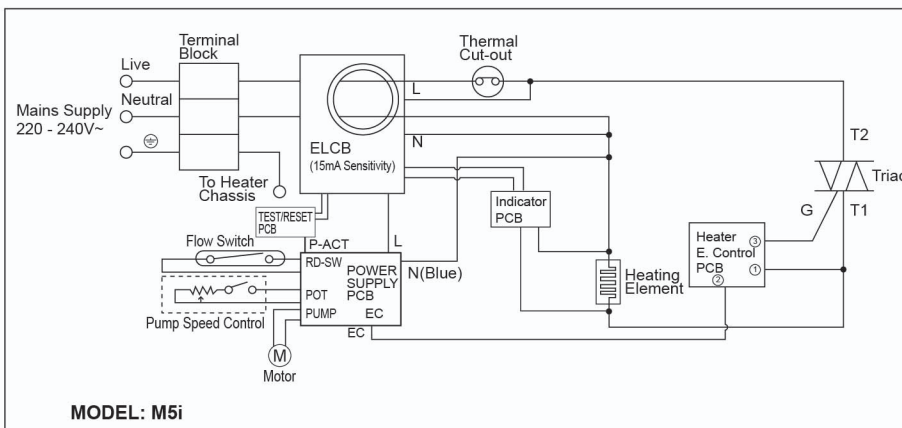
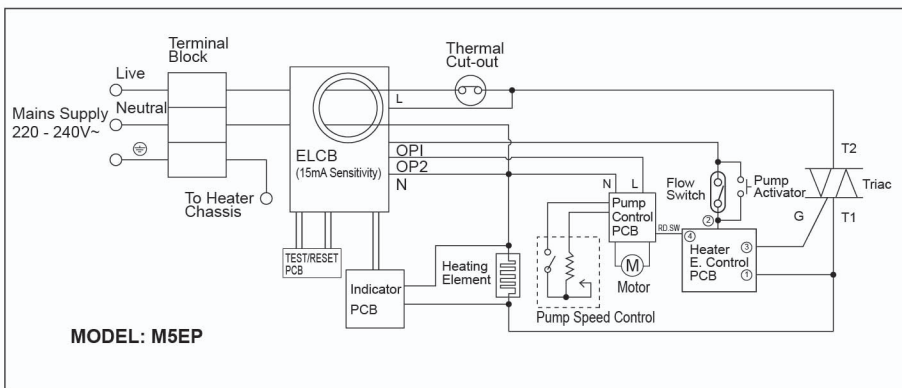
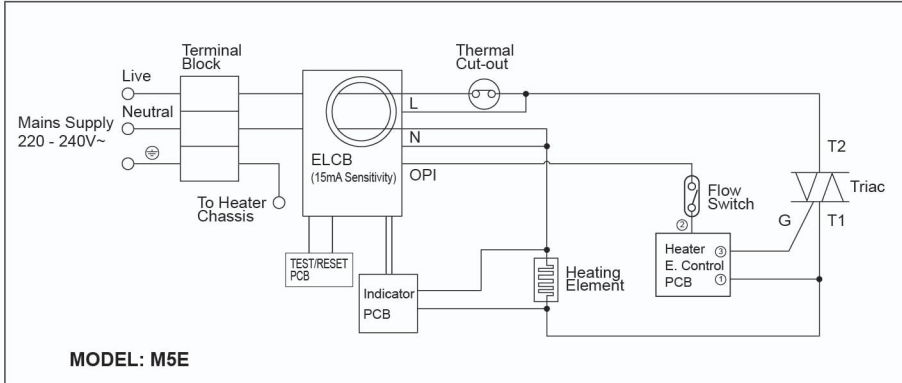

## GENERAL INFORMATION

### SPECIFICATIONS

Heater Power Rating	M5E	3.60kW 240V ~ 50Hz
	M5EP	3.72kW 240V~ 50Hz
	M5i	3.66kW 240V~ 50Hz
Others Power Rating	Refer to Electrical Loading Table for reference	
Water Connection	Ø 15.0mm (½" BSP)	
Operating Condition	Open Outlet	
Protection Against Electric Shock	Class I	
Water Temperature Control	Electronics	
Degree Of Protection	IP25	
Minimum Flow Rate	3 liters / minute	
Minimum Pressure	20kPa (0.2 bar / 2.9 psi)	
Maximum Inlet Pressure	0.38MPa (3.8 bar / 55psi)	
Heater Dimension	235mm (W) x 404mm (L) x 92mm (H)	
Heater Nett Weight	M5E	1.6kg
	M5EP	2.6kg
	M5i	2.2kg

ALPHA M5E/EP/i (M) H01A00118 12.05.2018

- \* Due to the minor changes in design or otherwise the picture(s) shown in this manual may sometimes differ from the actual.
- \* All rights reserved. No part of this publication may be reproduced, stored in a retrieval system, or transmitted, in any form or by any means, without prior permission in writing of Alpha Electric Co Sdn Bhd.